

# TOTO®

Perfection by Design

## Battery Powered (6V, DC) Sensor Toilet Flush Valve, Exposed - 1.6 GPF

To be specified:

### Sensor Toilet Flush Valve

- Valve Only, Nickel Chrome Plated Finish
  - Left and Right Rough - TET1DNC
- Complete Set, Nickel Chrome Plated Finish
  - Left and Right Rough - TET1DNC-32 (1 1/2" V.B.)

Complete Set Supplied With:

- Vacuum Breaker & Angle Stop Set - VB9CP-32
  - 1" Angle Stop - 10077t3
  - 1 1/2" Vacuum Breaker - 10075t1
  - Spud Nut & Escutcheon - 71051Nt6
  - Sweat Solder Kit - TH559EDVSJ3

*Meets the American Disabilities Act Guidelines and ANSI A117.1 requirements for people with disabilities.*



TET1DNC-32

### AUTOMATIC FLUSHING SYSTEM

TOTO, the world leader in advanced plumbing systems, provides sensor operated flush valves for facilities demanding the finest sanitation equipment for busy restrooms. "Hands-free" technology effectively reduces unsanitary conditions from unflushed fixtures.

### SUPERIOR PISTON VALVE

TOTO's piston valve technology is a marked improvement over the traditional "rubber diaphragm" valve. Not only does the longer piston travel and self-cleaning screen reduce common problems like sticking and flooding, but the piston itself will not warp or mis-seal, significantly reducing repair and maintenance cost.

### NEUTRAL ROUGH-IN

TOTO's sensor flush valve has neutral rough-in, it can be used as right or left rough-in with no modifications.

### OPERATING PROCEDURE A sanitary environment without using the hands.



The infrared sensor detects a user sitting on the toilet seat.



After using over 5 seconds, when a user leaves the fixture, the sensor automatically sends a signal to the operating unit to activate the flush valve.

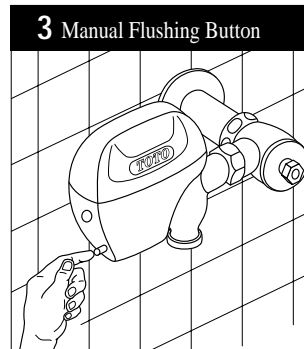



Valve is equipped with a manual flushing button.



Reliance Commercial Line

# Battery Powered(6V, DC) Sensor Toilet Flush Valve, Exposed - 1.6 GPF

## SPECIFICATIONS

<b>Product</b>	TET1DNC - Valve Only, Left and Right Rough, Chrome Plated Finish TET1DNC-32 - Complete Set (1 1/2"V.B.), Left and Right Rough, Chrome Plated Finish
<b>Power supply</b>	Four AA alkaline batteries, included. 2 year life, based on 4000 cycles per month
<b>Detection range</b>	Self-adjusting to environment
<b>Detection time</b>	Factory setting at five (5) seconds minimum
<b>Water supply pipe</b>	1" NPT
<b>Discharge quantity</b>	Factory setting at 1.6 Gpf
<b>Toilet type</b>	Flushometer type bowl
<b>Trap seal protection</b>	Automatic flushing once every twenty four (24) hours, if not used
<b>Ambient temperature</b>	32°-104°F (0°-40°C)
<b>Supply water pressure</b>	Minimum required water pressure: 15psi(flowing) Maximum water pressure: 125psi*
<b>Warranty</b>	Limited one (1) year warranty on all component parts. Details available upon request.
<b>Listings</b>	 City of Los Angeles  A.S.S.E. 1037

*These dimensions and specifications are subject to change without notice.  
\*Water pressures over 80 psi are not recommended for most plumbing fixtures.*

## SUGGESTED ENGINEERING SPECIFICATION:

TOTO Model No. \_\_\_\_\_ year life at 4,000 cycles/month. 1.6 gallon flush with manual  
Automatic infrared sensor activated bronze piston override button. Piston valve with stainless self-cleaning debris  
toilet flush valve. Heavy duty zinc casted covers. Vandal screen. Automatic flush every twenty four hours if not used.  
resistant mounting screws. Four AA alkaline batteries with a 2 Angle stop and vacuum breaker included.

## DIAGRAM:

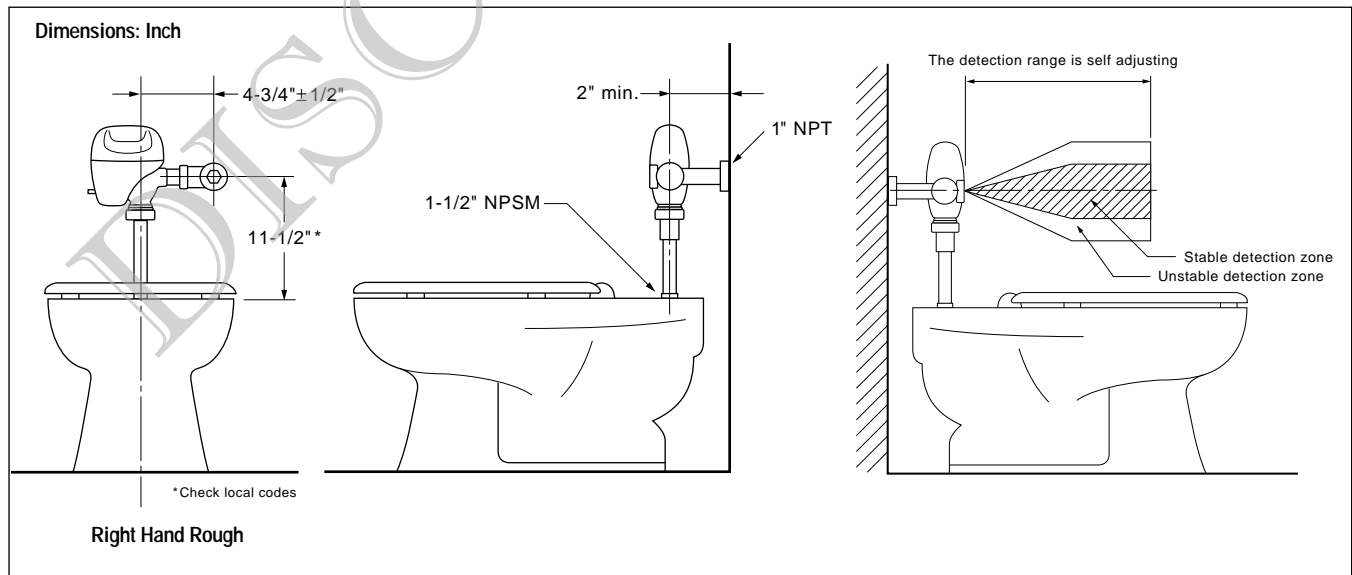

**TOTO®**  
Perfection by Design

TOTO U.S.A., INC. • 1155 Southern Road, Morrow, GA 30260  
Tel. (770) 282-8686 • Fax. (770) 282-8701 • www.totousa.com

TOTO KIKI U.S.A. is a wholly owned subsidiary of TOTO LTD. Printed in U.S.A. © TOTO LTD. 3/99

Printed on recycled paper 